

Listen and Number 請依據所聽到的內容，將題號寫在正確圖示的上方框框中。例：



Identify

第一部分：1~3 題



第二部分：1~3 題



第三部分：1~3 題

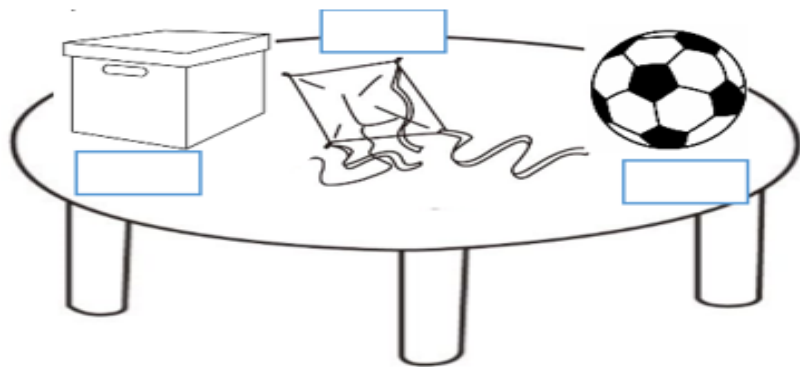

錄音稿

四年級聽力評量，第一到第三部份，請依據所聽到的內容，直接在試卷上的圖示寫出對應題號的數字，例如播音內容是對應第一題的圖，就在圖上寫 1。共有 9 題。每題的內容均播放兩次。(停 2 秒)

現在開始播放第一部分(停 2 秒)

Number 1 (停 1 秒) It's nine o'clock. (停 2 秒) It's nine o'clock. (停 3 秒)

Number 2 (停 1 秒) It's ten-thirty. (停 2 秒) It's ten-thirty. (停 3 秒)

Number 3 (停 1 秒) It's twelve twenty-five. (停 2 秒) It's twelve twenty-five. (停 3 秒)

現在開始播放第二部分(停 2 秒)

Number 1 (停 1 秒) He is eating. (停 2 秒) He is eating. (停 3 秒)

Number 2 (停 1 秒) She is sleeping. (停 2 秒) She is sleeping. (停 3 秒)

Number 3 (停 1 秒) He's singing. (停 2 秒) He's singing. (停 3 秒)

現在開始播放第三部分(停 2 秒)

Number 1 (停 1 秒) This is a box. (停 2 秒) This is a box. (停 3 秒)

Number 2 (停 1 秒) It's a ball. (停 2 秒) It's a ball. (停 3 秒)

Number 3 (停 1 秒) This is a kite. (停 2 秒) This is a kite. (停 3 秒)

第四部份為是非題，請看圖並仔細聽，確認所聽到訊息是否與圖呈現的內容符合，符合的在框框中寫 Y，不符合的在框框中寫 N (停 10 秒) 現在開始播放 Part 1 第 1 到 3 題。(停 2 秒)

Number 1 (停 1 秒)

M: Where is Jack?

W: He's in the living room

(停 1 秒)

M: Where is Jack?

W: He's in the living room

第四部分是非題。請看圖並仔細聽。確認所聽到的訊息是否與圖畫的內容符合，如果符合，請在圖片上方框框中寫 O，不符合請寫 X。



第五部分選擇題：請依據所聽到的問題，參考圖示，選擇一個正確的回應，並將答案寫在括弧中。

- 1.() 2.()

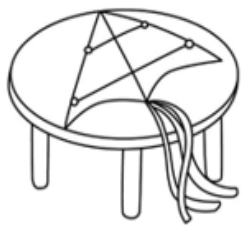

- 3.() 4.()



- 5.()



圖，不符合的在框框中寫 X (停 10 秒) 現在開始播放 Part 1 第 1 到 3 題。(停 2 秒)

Number 1 (停 1 秒)

M: Where is Jack?

W: He's in the living room

(停 1 秒)

M: Where is Jack?

W: He's in the living room

(停 2 秒)

Number 2 (停 1 秒)

M: Peter is my brother. He is in the bedroom now.

(停 1 秒)

M: Peter is my brother. He is in the bedroom now.

(停 2 秒)

Number 3

M: What is Danny doing?

W: He is running in the yard

(停 1 秒)

M: What is Danny doing?

W: He is running in the yard

(停 2 秒)

第五部份選擇題。以下 1-5 題為選擇題，每題均由問句開始，請依據所聽到的問題，參考圖例，選擇一個正確的回應方式，再將正確回應該案寫在空格中。(停 10 秒)

現在開始播放第四部分。

Number 1 (停 1 秒)

Question: Where's his kite? (停 2 秒)

1. His kite is new.
2. It's a cute kite
3. It's on the table.

(停 1 秒)

Question: Where's his kite? (停 2 秒)

1. His kite is new.
2. It's a cute kite
3. It's on the table.

(停 3 秒)

Part A 請仔細聽，依照對話內容，將出現的物品依照所聽到的位置參考右下圖的圖例，畫在正確的位置上。共有 3 題。

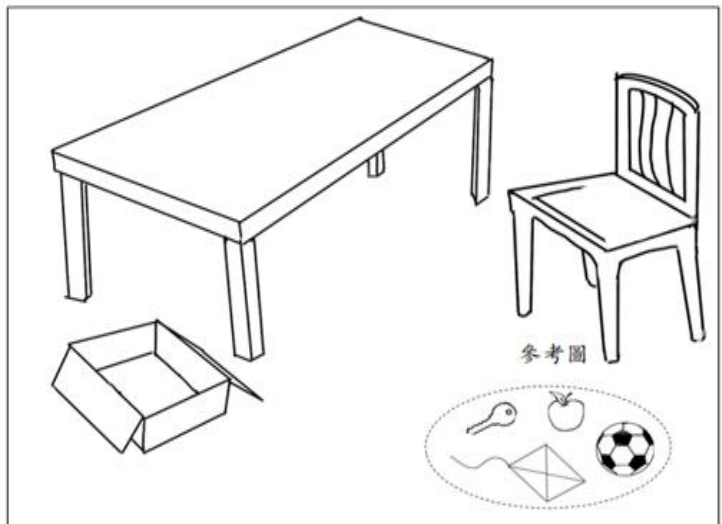

Part B 請看圖並仔細聽，確認你聽到的訊息是與下圖中哪一部分的圖示所呈現的內容符合，請在圖示旁邊的框框中寫出題號。(共有 4 小題，請依聽到的題目順序寫出號碼)



第六部份為聽題。分為 Part A 和 Part B 兩部份，Part A 請仔細聽，將出現的物品依照所聽到的位置參考右下圖的圖例，畫在正確的位置上。一共有三題。

開始播放 Part A。(停 1 秒)

第一題

Mom: Look! Your key is on the chair.

Girl: Thank you, Mom.

(停 1 秒)

Mom: Look! Your key is on the chair.

Girl: Thank you, Mom. (停 3 秒)

第二題

Girl: Mom, where's my ball?

Mom: It's under the table.

(停 1 秒)

Girl: Mom, where's my ball?

Mom: It's under the table. (停 3 秒)

第三題

Boy: Dad, Is my kite in the box?

Dad: No, it's on the table.

(停 1 秒)

Boy: Dad, Is my kite in the box?

Dad: No, it's on the table. (停 3 秒)

Part B, 請看圖並仔細聽，確認所聽到的訊息是與哪一部分的圖示呈現的內容符合，在圖示旁邊的框框中寫數字，一共有 4 小題。(停 10 秒) 現在開始播放 Part B。(停 1 秒)

- | | |
|--|--|
| 1. My sister is drinking coke. (停 1 秒) | 1. My sister is drinking coke. (停 3 秒) |
| 2. Tom is swimming. (停 1 秒) | 2. Tom is swimming. (停 3 秒) |
| 3. My father is sleeping. (停 1 秒) | 3. My father is sleeping. (停 3 秒) |
| 4. My Grandfather is eating a hamburger. (停 1 秒) | 4. My Grandfather is eating a hamburger. (停 3 秒) |

(聽力播音完畢)

Listen and Do

Identify

identify

第一部分：第 1-7 題，請選出一個最適當的答案。

1. ()

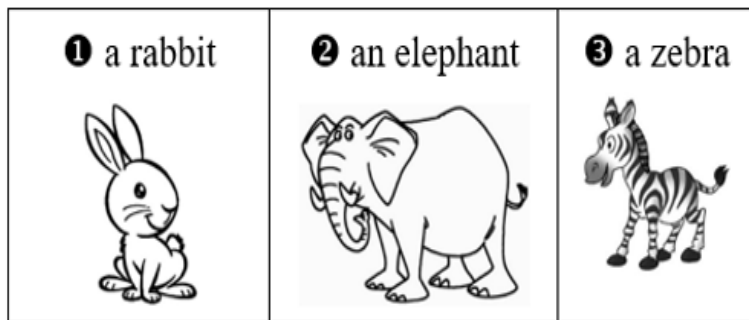

2. ()

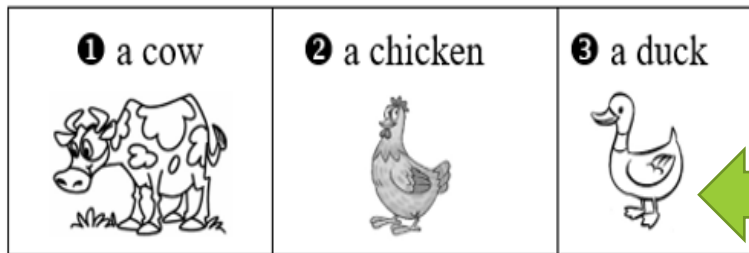

3. ()

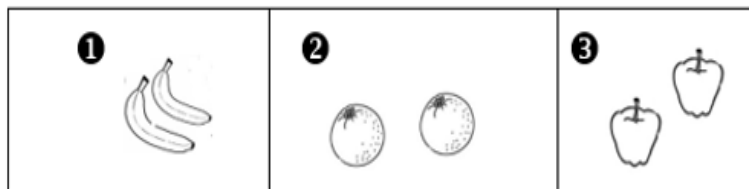

4. () **1** 4:00. **2** 5:00. **3** 6:00.
5. () **1** The trash. **2** The man. **3** Hiking.
6. () **1** In his room. **2** On his face. **3** On his head.
7. () **1** It's Monday. **2** It's Tuesday. **3** It's Sunday.

每題的內容及問題均播放兩次。

(停 2 秒)

現在開始播放第一部分。

(停 2 秒)

Number 1 (停 1 秒)

I like to eat grass. I am big and gray. I have a long nose. Who am I?

(停 2 秒)

I like to eat grass. I am big and gray. I have a long nose. Who am I?

(停 3 秒)

(停 2 秒)

Number 2 (停 1 秒)

I can walk. I can swim, too. I have two legs. Who am I?

(停 2 秒)

I can walk. I can swim, too. I have two legs. Who am I?

(停 3 秒)

(停 2 秒)

Number 3 (停 1 秒)

M: Do you like apples and bananas?

W: No, I don't like apples or bananas. Oranges are my favorite.

(停 1 秒)

Question: What fruit does the woman like?

(停 2 秒)

M: Do you like apples and bananas?

W: No, I don't like apples or bananas. Oranges are my favorite.

(停 1 秒)

Question: What fruit does the woman like?

(停 3 秒)

4. () ❶ 4:00. ❷ 5:00. ❸ 6:00.
5. () ❶ The trash. ❷ The man. ❸ Hiking.
6. () ❶ In his room. ❷ On his face. ❸ On his head.
7. () ❶ It's Monday. ❷ It's Tuesday. ❸ It's Sunday.

Listen for information

M: It's 4 o'clock now. Let's meet at the park at 6 o'clock.

W: OK. See you.

(停 1 秒)

Question: What time are the man and the woman going to meet?

(停 2 秒)

M: It's 4 o'clock now. Let's meet at the park at 6 o'clock.

W: OK. See you.

(停 1 秒)

Question: What time are the man and the woman going to meet?

(停 3 秒)

(停 2 秒)

Number 5 (停 1 秒)

M: You look angry. You don't like hiking?

W: Yes, I do. But look at all the trash over there!

(停 1 秒)

Question: What is the woman angry about?

(停 2 秒)

M: You look angry. You don't like hiking?

W: Yes, I do. But look at all the trash over there!

(停 1 秒)

Question: What is the woman angry about?

(停 3 秒)

(停 2 秒)

Number 6 (停 1 秒)

M: I can't find my glasses in my room.

W: They're on your head.

M: Ha! Thank you!

(停 1 秒)

Question: Where are the man's glasses?

(停 2 秒)

M: I can't find my glasses in my room.

W: They're on your head.

M: Ha! Thank you!

(停 1 秒)

Question: Where are the man's glasses?

第二部分：題組

(第 8-9 題) 請選出一個最適當的答案。

8. () ① He's 9. ② He's 11. ③ He's 15.

9. () ① His mom. ② His dad. ③ His sister.

(第 10-12 題) 請選出一個最適當的答案。

10. () ① It's rainy. ② It's sunny. ③ It's windy.

11. () ① To see tigers and lions. ② To play in the rain. ③ To buy umbrellas.

12. () ① Yes. ② No.

(第 13-15 題)

13. 請圈選東西種類及數量。

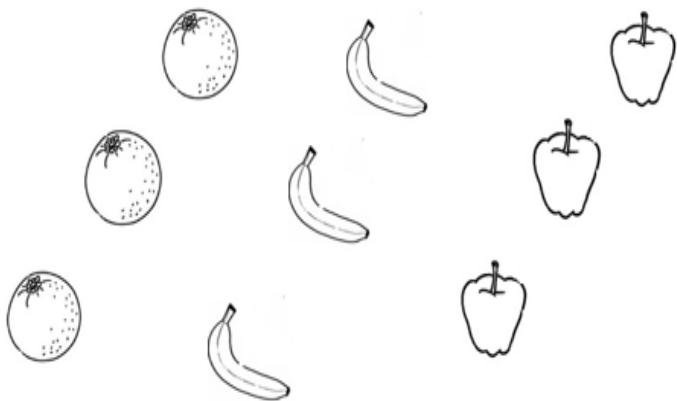

14. () 請選出一個最適切的答案。(對話中的男子，共要付多少錢?)

① \$10. ② \$50. ③ \$60.

15. 請簡答 (用中、英文作答皆可) _____

Number 7 (停 1 秒)

W: I want to go to the City Museum.

M: Well... it's not open today. It is open from Tuesday to Sunday.

W: Then let's go there tomorrow.

(停 1 秒)

Question: What day is today?

(停 2 秒)

W: I want to go to the City Museum.

M: Well... it's not open today. It is open from Tuesday to Sunday.

W: Then let's go there tomorrow.

(停 1 秒)

Question: What day is today?

(停 3 秒)

Listen for information

(停 2 秒)

第二部份題組。以下第 8-15 題為題組題，每個題組有兩到三個題目，請依據所聽到的內容及問題，直接在試卷上選出一個最適當的答案。每題的內容及問題均播放兩次。現在請先看一遍試卷上的第 8-15 題。(停 20 秒)

現在開始播放第二部分。

(停 2 秒)

For Number 8 and Number 9 (停 1 秒)

Today is Eric's birthday. He's eleven years old. He has some presents from his family. The bag is from his mom; the shirt is from his dad; and the hat is from his sister. (停 1 秒)

Number 8: How old is Eric? (停 3 秒)

Number 9: Who gives Eric the shirt? (停 3 秒)

(停 2 秒)

For Number 8 and Number 9 (停 1 秒)

Today is Eric's birthday. He's eleven years old. He has some presents from his family. The bag is from his mom; the shirt is from his dad; and the hat is from his sister. (停 1 秒)

Number 8: How old is Eric? (停 3 秒)

Number 9: Who gives Eric the shirt? (停 3 秒)